

T102M

TESTE PORTACOLTELLI PER SPIANARE, PER SCORNICIATRICI MODULAR PLANER CUTTERHEADS WITH DISPOSABLE KNIVES



D mm	B mm	d* mm	Z	R	CODICE CODE
125	50	40	4		T102M AC3
125	50	50	4		T102M AD3
125	30	40 (50)	4		T102M AF3

PARTI DI RICAMBIO SPARE PARTS		DIMENSIONI DIMENSIONS		CODICE CODE
AC3 AD3	Coltello / Knife		50 x 12 x 1,5	CG01M FA3
	Cuneo / Wedge		15 x 46 x 8	CN09M AP9
AF3	Coltello / Knife		30 x 12 x 1,5	CG01M EA3
	Cuneo / Wedge		15 x 26 x 8	CN09M AD9
	Vite / Screw		M10 x 22	VT19M MA9
	Ogiva / Nut		15 x 13,3 x 10	VT20M MA9
	Chiave / Allen key		5 x 110	CB03M EA9

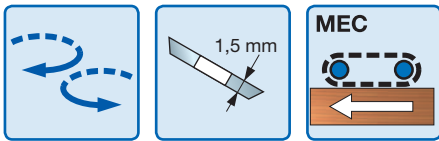

- > Utilizzabile in accoppiamento con utensili T182M.
- > Can be used in combination with item T182M to cut guiding rebates.

ARTICOLO ITEM	UTILIZZABILE CON: IN CONJUNCTION WITH ITEM:
T102M	T182M EA3
T102M	T182M EB3

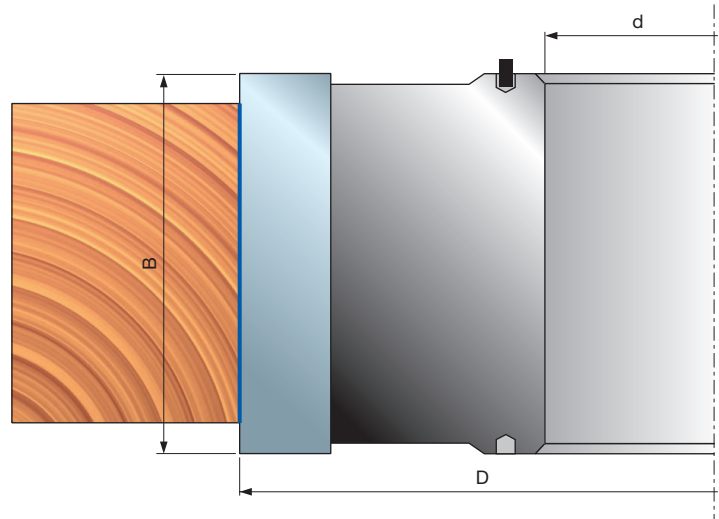
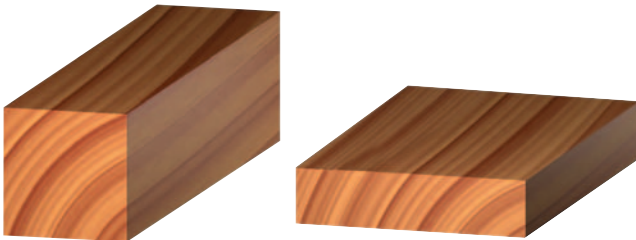

- > ESEMPI DI APPLICAZIONE
- > APPLICATION EXAMPLES

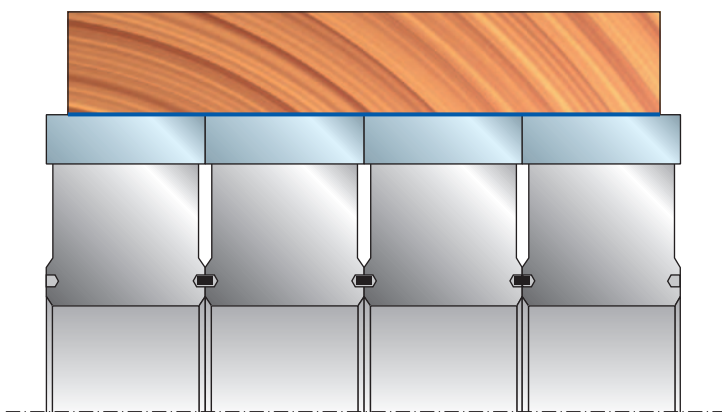

Fig. A

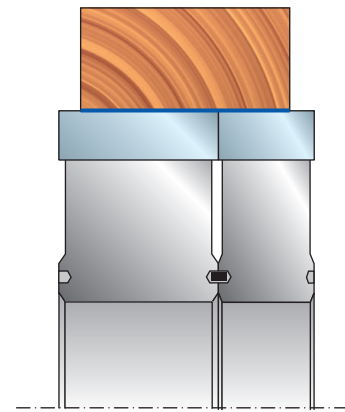
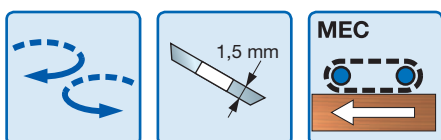

Fig. B

TM06M

TESTE PORTACOLTELLI PER SPIANARE - TAGLIENTI ELICOIDALI HELICAL PLANER CUTTERHEADS WITH DISPOSABLE KNIVES







- > Utilizzabile in accoppiamento con utensili T182M.
- > Can be used in combination with item T182M to cut guiding rebates.

ARTICOLO ITEM	UTILIZZABILE CON: IN CONJUNCTION WITH ITEM:
TM06M Ø125	T182M AB3
TM06M Ø125	T182M AA3
TM06M PC3 - TM06M PH3	T182M CB3
TM06M	T182M DB3

D mm	B* mm	d mm	Z	R	CODICE CODE
100	113	35	12		TM06M PC3
100	183	35	20		TM06M PH3
125	78,5	40	12		TM06M AB3
125	130	40	21		TM06M AD3
125	148,5	40	24		TM06M AF3
125	183,5	40	30		TM06M AH3
125	201	40	33		TM06M AI3
125	236	40	39		TM06M AM3

- > *La misura "B" indica lo spessore utile di taglio; l'ingombro totale dell'utensile è B + 3,5 mm.
- > *Dimension "B" indicates effective cutting length. The maximum tool length is B + 3,5 mm.

PARTI DI RICAMBIO SPARE PARTS	DIMENSIONI DIMENSIONS	CODICE CODE
Coltello / Knife	 24 x 12 x 1,5	CG18M BC3
Cuneo / Wedge	 15 x 19,3 x 8	CN09M AM9
Vite / Screw	 M10 x 22	VT19M MA9
Ogiva / Nut	 15 x 13,3 x 10	VT20M MA9
Chiave / Allen key	 5 x 110	CB03M EA9

- > Corpo in lega leggera (ERGAL). Per la pulizia non utilizzare prodotti contenenti soda caustica. Non è consentita l'allargatura del foro. Per grosse asportazioni di legno, con buona finitura, fino ad uno spessore massimo di 20 mm.
- > Light alloy body (ERGAL). For cleaning do not use products containing caustic soda. Rebore not available. Gives a good finish when cutting a maximum depth of 20 mm.



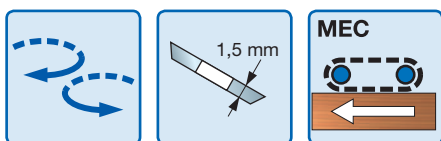

TM07M

TESTE PORTACOLTELLI PER SPIANARE - TAGLIENTI INTERCALATI PLANER CUTTERHEADS WITH OVERLAPPING, DISPOSABLE KNIVES



ARTICOLO ITEM	UTILIZZABILE CON: IN CONJUNCTION WITH ITEM:
TM07M Ø125	T182M AB3
TM07M AF3	T182M BB3
TM07M	T182M AA3
TM07M	T182M DB3

D mm	B mm	d mm	Z	R	CODICE CODE
125	130	40	9		TM07M GD3
125	138	40	9		TM07M GE3
125	180	40	12		TM07M GF3
125	226	40	15		TM07M GG3

PARTI DI RICAMBIO SPARE PARTS	DIMENSIONI DIMENSIONS	CODICE CODE
Coltello / Knife	 50 x 12 x 1,5	CG18M FC3
Cuneo / Wedge	 15 x 46 x 8	CN09M AP9
Vite / Screw	 M10 x 22	VT19M MA9
Ogiva / Nut	 15 x 13,3 x 10	VT20M MA9
Chiave / Allen key	 5 x 110	CB03M EA9

- > Corpo in lega leggera (ERGAL). Per la pulizia non utilizzare prodotti contenenti soda caustica. Non è consentita l'allargatura del foro. Per asportazioni normali di legno (5-6 mm), con buona finitura.
- > Light alloy body (ERGAL). For cleaning do not use products containing caustic soda. Rebore not available. Gives a good finish when cutting a maximum depth of 5-6 mm.
- > Utilizzabile in accoppiamento con utensili T182M.
- > Can be used in combination with item T182M to cut guiding rebates.

TM17M

TESTE PER SPIANARE ISOPROFIL ISOPROFIL PLANER CUTTERHEADS



- > Utensili con coltelli in HW
- > Tools supplied with HW knives

D mm	B mm	d mm	Z	R	CODICE CODE
125	80	40	2		TM17M AA3
125	130	40	2		TM17M AD3
125	150	40	2		TM17M AF3
125	180	40	2		TM17M AH3
125	240	40	2		TM17M AM3

- > Utensili con coltelli in HSS
- > Tools supplied with HSS knives

D mm	B mm	d mm	Z	R	CODICE CODE
125	80	40	2		TM17M AA2
125	130	40	2		TM17M AD2
125	150	40	2		TM17M AF2
125	180	40	2		TM17M AH2
125	240	40	2		TM17M AM2

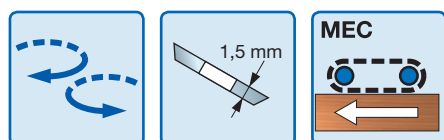

ISOPROFIL®

**BREVETTO
REGISTRATO**

**REGISTERED
PATENT**

> Teste con angolo assiale e coltelli in metallo duro micrograno di nuova generazione (X10TS). Massima finitura nelle basse asportazioni (fino a 3 mm); particolarmente indicate per la lavorazione di legni teneri. È possibile costruire le nuove teste per pialla anche con misure diverse da quelle standard indicando, al momento dell'ordine, diametro, lunghezza e foro. La produzione è soggetta all'approvazione del nostro dipartimento tecnico.

> Cutterheads with shear angle and knives in hard metal micrograin of a new generation (X10TS). Top finish when removing small material quantity (up to 3 mm); particularly well suited for softwood. It is possible to manufacture the new planer heads with different dimensions respect to the standard ones, indicating, in the order, diameter, length and bore. The production is subject to the approval of our technical department.

> Utilizzabile in accoppiamento con utensili T182M.

> Can be used in combination with item T182M to cut guiding rebates.

ARTICOLO ITEM	UTILIZZABILE CON: IN CONJUNCTION WITH ITEM:
TM17M	T182M EA3
TM17M	T182M EB3

PARTI DI RICAMBIO SPARE PARTS	DIMENSIONI DIMENSIONS	CODICE CODE
Cuneo / Wedge	82 x 19,5 x 10	CN14M AA9
Coltello in HW / HW knife	82 x 19 x 4,5	CP10M AA3
Coltello in HSS / HSS knife	82 x 19 x 4,5	CP10M AA2
Cuneo / Wedge	132 x 19,5 x 10	CN14M AD9
Coltello in HW / HW knife	132 x 19 x 4,5	CP10M AD3
Coltello in HSS / HSS knife	132 x 19 x 4,5	CP10M AD2
Cuneo / Wedge	152 x 19,5 x 10	CN14M AF9
Coltello in HW / HW knife	152 x 19 x 4,5	CP10M AF3
Coltello in HSS / HSS knife	152 x 19 x 4,5	CP10M AF2
Cuneo / Wedge	182 x 19,5 x 10	CN14M AH9
Coltello in HW / HW knife	182 x 19 x 4,5	CP10M AH3
Coltello in HSS / HSS knife	182 x 19 x 4,5	CP10M AH2
Cuneo / Wedge	242 x 19,5 x 10	CN14M AM9
Coltello in HW / HW knife	242 x 19 x 4,5	CP10M AM3
Coltello in HSS / HSS knife	242 x 19 x 4,5	CP10M AM2

> Corpo in lega leggera (ERGAL). Per la pulizia non utilizzare prodotti contenenti soda caustica.

> Light alloy body (ERGAL). For cleaning do not use products containing caustic soda.

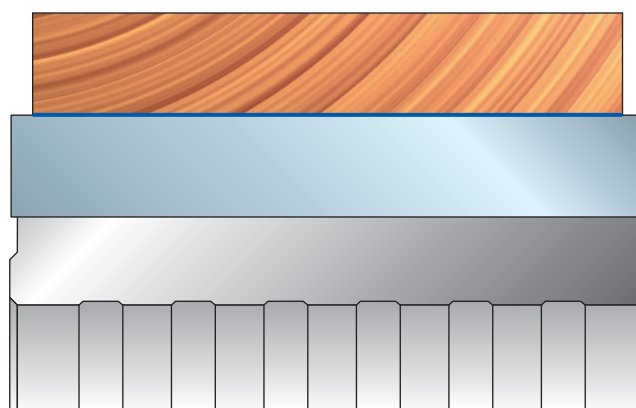

TM18M

TESTE PER SPIANARE ISOPROFIL ISOPROFIL PLANER CUTTERHEADS

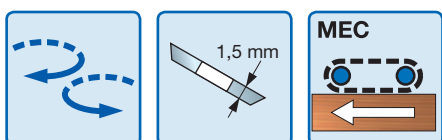

ISOprofil®

**BREVETTO
REGISTRATO**

**REGISTERED
PATENT**

> Teste con angolo assiale e coltelli in metallo duro micrograno di nuova generazione (X10TS). Massima finitura nelle basse asportazioni (fino a 3 mm); particolarmente indicate per la lavorazione di legni teneri. È possibile costruire le nuove teste per pialla anche con misure diverse da quelle standard indicando, al momento dell'ordine, diametro, lunghezza e foro. La produzione è soggetta all'approvazione del nostro dipartimento tecnico.

> Cutterheads with shear angle and knives in hard metal micrograin of a new generation (X10TS). Top finish when removing small material quantity (up to 3 mm); particularly well suited for softwood. It is possible to manufacture the new planer heads with different dimensions respect to the standard ones, indicating, in the order, diameter, length and bore. The production is subject to the approval of our technical department.

> Utilizzabile in accoppiamento con utensili T182M.

> Can be used in combination with item T182M to cut guiding rebates.

ARTICOLO ITEM	UTILIZZABILE CON: IN CONJUNCTION WITH ITEM:
TM18M	T182M EA3
TM18M	T182M EB3

- > Utensili con coltelli in HW
- > Tools supplied with HW knives

D mm	B mm	d mm	Z	R	CODICE CODE
125	80	40	4		TM18M AA3
125	130	40	4		TM18M AD3
125	150	40	4		TM18M AF3
125	180	40	4		TM18M AH3
125	230	40	4		TM18M AP3
125	240	40	4		TM18M AM3

- > Utensili con coltelli in HSS
- > Tools supplied with HSS knives

D mm	B mm	d mm	Z	R	CODICE CODE
125	80	40	4		TM18M AA2
125	130	40	4		TM18M AD2
125	150	40	4		TM18M AF2
125	180	40	4		TM18M AH2
125	230	40	4		TM18M AP2
125	240	40	4		TM18M AM2

	PARTI DI RICAMBIO SPARE PARTS		DIMENSIONI DIMENSIONS	CODICE CODE
AA2-AA3	Cuneo / Wedge		82 x 19,5 x 10	CN14M AA9
	Coltello in HW / HW knife		82 x 19 x 4,5	CP10M AA3
	Coltello in HSS / HSS knife		82 x 19 x 4,5	CP10M AA2
AD2-AD3	Cuneo / Wedge		132 x 19,5 x 10	CN14M AD9
	Coltello in HW / HW knife		132 x 19 x 4,5	CP10M AD3
	Coltello in HSS / HSS knife		132 x 19 x 4,5	CP10M AD2
AF2-AF3	Cuneo / Wedge		152 x 19,5 x 10	CN14M AF9
	Coltello in HW / HW knife		152 x 19 x 4,5	CP10M AF3
	Coltello in HSS / HSS knife		152 x 19 x 4,5	CP10M AF2
AH2-AH3	Cuneo / Wedge		182 x 19,5 x 10	CN14M AH9
	Coltello in HW / HW knife		182 x 19 x 4,5	CP10M AH3
	Coltello in HSS / HSS knife		182 x 19 x 4,5	CP10M AH2
AP2-AP3	Cuneo / Wedge		242 x 19,5 x 10	CN14M AP9
	Coltello in HW / HW knife		242 x 19 x 4,5	CP10M AP3
	Coltello in HSS / HSS knife		242 x 19 x 4,5	CP10M AP2
AM2-AM3	Cuneo / Wedge		242 x 19,5 x 10	CN14M AM9
	Coltello in HW / HW knife		242 x 19 x 4,5	CP10M AM3
	Coltello in HSS / HSS knife		242 x 19 x 4,5	CP10M AM2

> Corpo in lega leggera (ER GAL). Per la pulizia non utilizzare prodotti contenenti soda caustica.

> Light alloy body (ER GAL). For cleaning do not use products containing caustic soda.

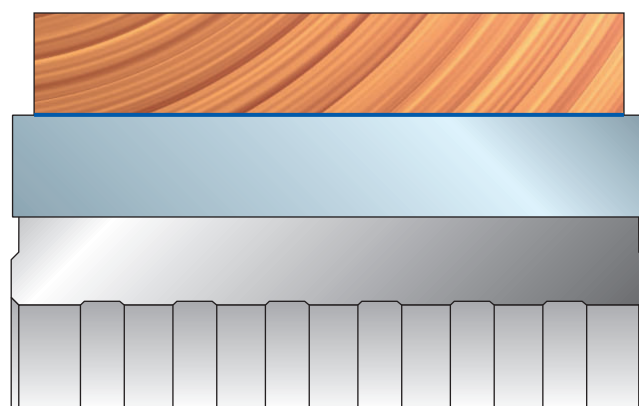

T182M

TESTE PORTACOLTELLI PER SCANALATURE DI GUIDA LATERALE GROOVE BED CUTTERHEADS WITH DISPOSABLE KNIVES



D mm	B mm	d mm	Z	R	CODICE CODE
150	10	40	4	2	T182M EB3
150	10	40	3	3	T182M DB3
145	12	40	4	2	T182M EA3
145	12	40	3	3	T182M AA3
145	10	40	3	3	T182M AB3*
120	12	35	3	3	T182M BB3
120	12	35	2	2	T182M CB3

> **Art. T182M:** Si utilizza in accoppiamento con utensili TM06M-TM07M.

> **Item T182M:** For use in combination with TM06M-TM07M to cut guiding rebates.

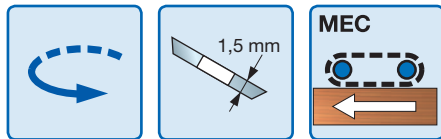

ARTICOLO ITEM	UTILIZZARE CON: IN CONJUNCTION WITH ITEM:
T182M AB3*	TM06M - TM07M Ø125
T182M BB3	TM07M AF3
T182M AA3	TM06M - TM07M Ø125
T182M CB3	TM06M PC3 - TM06M PH3
T182M DB3	TM06M - TM07M
T182M EA3	TM17M - TM18M - T102M
T182M EB3	TM17M - TM18M - T102M

> * Va montata su scorniciatrici Casadei e S.C.M.

> * For use on Casadei and S.C.M. moulders.

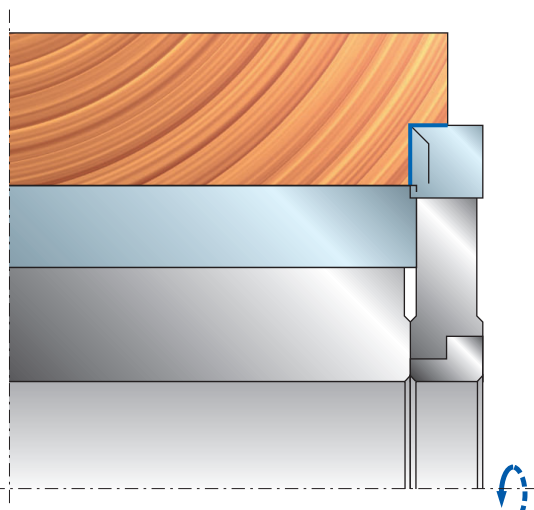
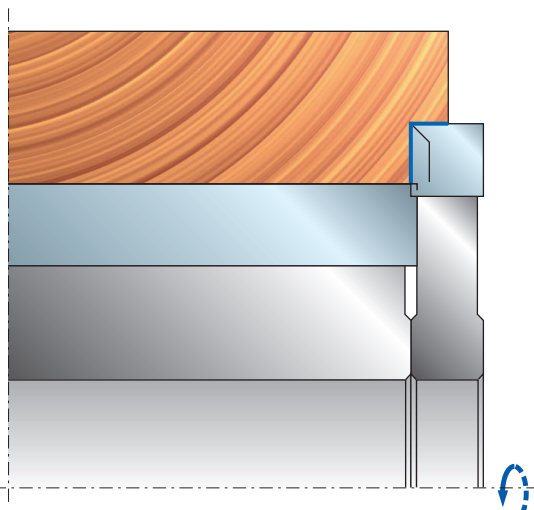







	PARTI DI RICAMBIO SPARE PARTS	DIMENSIONI DIMENSIONS	CODICE CODE
AA3	Coltello / Knife	12 x 12 x 1,5	CG01M BA3
	Cuneo / Wedge	15 x 10 x 8	CN01M BA9
	Flangia / Flange	68 x 10 x 40	FX01M HC9
AB3	Vite / Screw	M6 x 16	VT03M D19
	Coltello / Knife	9,6 x 12 x 1,5	CG01M MA3
	Cuneo / Wedge	15 x 8 x 8	CN09M DB9
BB3	Vite / Screw	M5 x 19	VT11M AA9
	Coltello / Knife	11 x 12 x 1,5	CG01M NA3
	Cuneo / Wedge	15 x 10 x 8	CN01M BA9
CB3	Vite / Screw	M6 x 16	VT03M D19
	Coltello / Knife	12 x 12 x 1,5	CG06M AA3
	Cuneo / Wedge	15 x 10 x 8	CN01M BA9
DB3	Vite / Screw	M6 x 16	VT03M D19
	Coltello / Knife	9,6 x 12 x 1,5	CG01M MA3
	Cuneo / Wedge	15 x 8 x 8	CN09M DB9
EA3	Vite / Screw	M5 x 16	VT03M BB9
	Coltello / Knife	12 x 12 x 1,5	CG01M BA3
	Cuneo / Wedge	15 x 10 x 8	CN09MS AA9
	Flangia / Flange	68 x 10 x 40	FX01M HC9
	Vite / Screw	M6 x 22	VT19M AB9
EB3	Ogiva / Nut	10 x 11,5 x 6	VT20M AA9
	Coltello / Knife	9,6 x 12 x 1,5	CG01M MA3
	Cuneo / Wedge	15 x 8 x 8	CN09M AH9
	Vite / Screw	M6 x 22	VT19M AB9
	Ogiva / Nut	9 x 10,5 x 6	VT20M GA9
	Rasante / Spur	14 x 14 x 2	RG01M AA3
	Vite / Screw	M5 x 8	VT05M AA9

T183M

TESTA PORTACOLTELLI PER SCANALATURE DI GUIDA LATERALE GROOVE BED CUTTERHEAD WITH DISPOSABLE KNIVES

D mm	B mm	d mm	Z	R	CODICE CODE
145	12	40	4	2	T183M AA3

- > **Art. T183M:** Per l'esecuzione di scanalature di guida su corniciatrice S.C.M.
- > **Item T183M:** For cutting guide grooves in solid wood for S.C.M. moulding machines.

PARTI DI RICAMBIO SPARE PARTS	DIMENSIONI DIMENSIONS	CODICE CODE
Coltello / Knife	 12 x 12 x 1,5	CG01M BA3
Cuneo / Wedge	 15 x 10 x 8	CN09MS AA9
Vite / Screw	 M6 x 22	VT19M AB9
Ogiva / Nut	 10 x 11,5 x 6	VT20M AA9
Rasante / Spur	 14 x 14 x 2	RG01M AA3
Vite / Screw	 M5 x 8	VT05M AA9
Chiave / Allen key	 3 x 110	CB03M AA9

